

2-EZ[®] HS / 2-EZ[®] SB 2-EZ[®] SB Plus



Case Erector/Bottom Taper

Combi Packaging Systems LLC is raising the bar for case erecting innovation with our high speed, side belt drive case erectors. Engineered with the industry's strongest frame (lifetime warranty) for the most demanding 3-shift environments, the 2-EZ[®]HS and 2-EZ[®]SB can readily integrate into your existing line at speeds up to 20 cpm. The 2-EZ[®] side belt drive units are designed for years of dependable service and can form and seal the widest variety of cases, from single wall to triple wall corrugated. With features that contribute to lowering your cost of ownership, Combi high speed case erectors have never been easier to maintain and operate.

Design Enhancements:

- No overhead cross members in doorways provides easy access for maintenance
- Hinged case hold down plate allows for easy tapehead removal
- Only 5 adjustment points with numbered scales - the tapehead and side belts adjust together
- Positive four flap closing - rotary actuators and a fixed guide close the major flaps which provides for smooth and gradual closing of the major flaps.
- Overall footprint reduced 8" freeing up valuable floor space
- Incorporated Piab vacuum generator at the cup resulting in half the amount of energy consumed
- Electrical enclosure now with 35% more panel space allowing for future integration of conveyor and other optional equipment



Positive Four Flap Closing

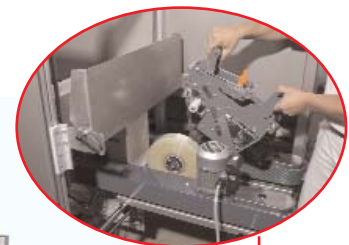

Hinged Hold Down Plate



2-EZ[®] HS / 2-EZ[®] SB / 2-EZ[®] SB Plus

2-EZ[®] HS Features:

- Up to 20 cases per minute (speed up kits available)
- EZ Load Walk-In 50" Power Magazine
- Positive Four Flap Closing
- Heavy-duty welded steel construction
- Combi HS High Speed 2" Tape Head
- Servo Driven Carriage Assembly
- Dual Belt Drive Case Indexing
- Self-Cleaning vacuum system

2-EZ[®] SB and 2-EZ[®] SB Plus Features:

- 2-EZ[®] SB Up to 15 cases per minute
- 2-EZ[®] SB Plus Up to 12 cases per minute
- EZ Load Walk-In Gravity Case Magazine
- Positive Four Flap Closing
- Heavy-duty welded steel construction
- 3M Accuglide II+™ 2" Tapehead
- Pneumatic Carriage Assembly
- Dual Belt Drive Case Indexing
- Self-Cleaning vacuum system

Electrical Service:

2-EZ [®] HS	230 volt / 3ph / 15A
2-EZ [®] SB	110 volt / 1ph / 15A
2-EZ [®] SB Plus	110 volt / 1ph / 15A

Model	Case Size Min. (LxWxH)	Case Size Max. (LxWxH)	Speed: Cases Per Minute*	Overall System Footprint (approx)
2-EZ HS	8" x 6" x 5"*** (203x152x127mm)	24" x 16" x 18" (610x406x457mm)	up to 20	8'4" x 9'4" (254x284cm)
2-EZ SB	8" x 6" x 5" (203x152x127mm)	20" x 16" x 18" (508x406x457mm)	up to 15	8'4" x 8'5" (254x257cm)
2-EZ SB Plus	8" x 6" x 5" (203x152x127mm)	24" x 16" x 18" (610x406x457mm)	up to 12	8'4" x 8'5" (254x257cm)

* Speeds are case size dependent

** Hot melt applications case size minimum 8" x 8" x 5"

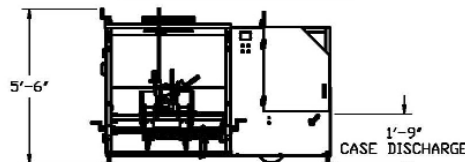
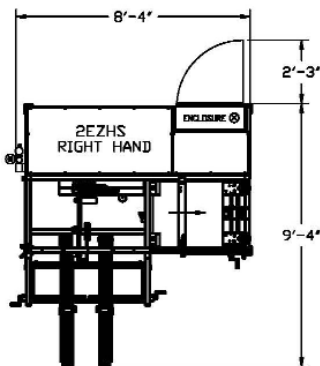

The Combi 2-EZ[®]HS, 2-EZ[®]SB and 2-EZ[®]SB Plus are capable of erecting and sealing the widest range of case sizes and styles.

RSC Regular Slotted Case
 CSSC With Meeting Minors
 RSC With 5th Panel Partition

Distributed by:

Combi
 Packaging Systems LLC

5365 East Center Dr NE Canton, OH 44721
 Phone: 800-521-9072 Fax: 330-456-4644
 www.combi.com

© 2009 Combi Packaging Systems