

# Ergopack® -

## Poly Bag Delivery System

The innovative Combi Ergopack has once again raised the standard for handpacking productivity. Introducing the new, modular poly bag delivery system. Efficient and durable, the Bag Delivery feature provides a dust-free and leakproof option for hand packing while maintaining the ergonomically designed hands-free indexing system exclusive to the Combi Ergopack.

The case erector automatically erects corrugated cases, then presents the case to the first operator where the bag liner is manually inserted into the case. A vacuum pulls the bag to the sides of the case. Once the case is lined, the case is presented to a second operator for hand packing product. Once the case is packed, the operator swipes a finger switch to send the case to an optional case sealer. Variable speed, product infeed conveyor and on-demand case presentation combined with available 1-, 2- or 3-operator stations provide ultimate flexibility.

### Features:

- Dust-free and Leakproof Environment
- Poly Bag Delivered on Demand
- Hands free case indexing system
- Vacuum Assisted Liner Insertion
- Tool less Poly Bag Roll Change
- PLC Controlled
- EZ Load, Walk-In Case Magazine
- Right or Left Hand Execution
- Modular System

### Options:

- Stainless Steel Framework
- Water washdown component packages
- Out of Bag Sensor
- Shaft for Spare Roll of Bags
- Spare Roll Storage Cart
- Packstations for 3 or more operators
- Low tape / No tape alarm system
- Low Case Supply Alarm
- Mobility Package



Ergonomically designed, the Poly Bag is delivered on demand, reducing reach and wrist movement



EZ load, walk-in Case Magazine



# Poly Bag Delivery System

## Additional Features:

- Heavy duty welded tubular steel construction
- Lifetime warranty on structural framework
- One-year warranty on non-wear parts\*
- Vacuum blowoff prevents corrugated dust build up
- Stainless Steel contact parts
- Lockout / tagout safety disconnect

## Electrical Service:

110 volt / Single phase - Bag Delivery System  
 230 volt / 3 Phase / 10A - Ergopack  
 (other options are available)

## Air Consumption:

80 psi, 5 CFM @ 12 cases per minute

## Minimum Product Infeed Height Formula:

Case discharge height + Height of tallest box +  
 Top flap height

## Standard Case Discharge Elevation:

21" to 28" (case dependent)

## Poly Bag Roll Size:

18" maximum diameter  
 22" maximum web width  
 1.5 to 6 mil material thickness

## Poly Bag Type:

Gusseted or non-gusseted; rolled type, perforated with  
 bottom seal



The Combi Poly Bag Delivery System offers hand packing versatility for:

Bulk Filling  
 Weigh Filling  
 Auger Filling

Ideal for the Food Industry:

Bakery Products  
 Snack Foods  
 Meat, Poultry  
 Fish, Seafood  
 Confectionery  
 Frozen Foods  
 Disposables

Model	Case Size Min. (LxWxH)	Case Size Max. (LxWxH)	Speed: Cases Per Minute	Overall System Footprint**
E-2500	8 1/2" x 4 3/4" x 4" 216 x 121 x 102mm	20" x 13 1/2" x 19 1/2" 508 x 343 x 495mm	12	9'3" x 18'9" 2819 x 5715mm

Ergopack systems with Poly Bag Insertion incorporates our standard E-2500 Case Erector. Larger systems can be quoted.

\*See warranty for details

\*\*Dimension stated for a two man pack station. Maximum case height is product dependent.

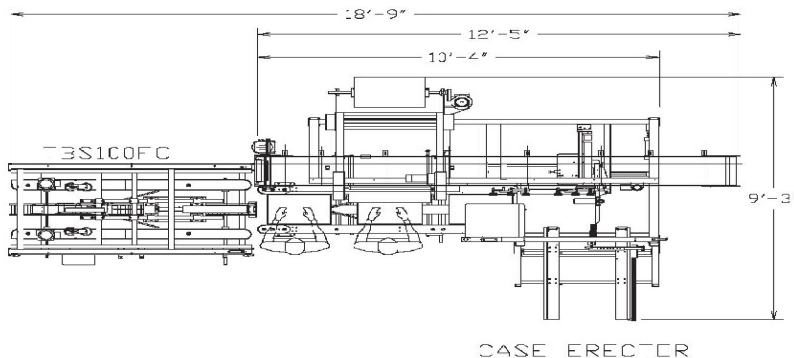
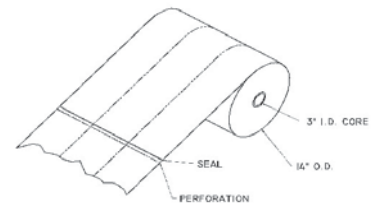
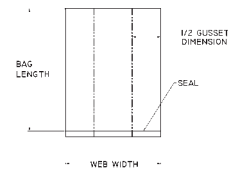

## Side view

