

TF-2

Tray Former



The TF-2 is a perfect solution for forming and gluing die cut trays. The TF-2 is a simple, intelligent and very compact system that utilizes the same transport mechanism as our E-Series case erectors. The TF-2 features a low-profile, gravity walk-in case magazine, and only 4 easy adjustments for tray changeover. The computer controlled glue application system applies glue very precisely to the tabs at measurable intervals, creating a very square and securely glued tray every cycle.

Features:

- Heavy duty welded tubular steel framework with steel-it paint finish
- Easy changeover with pre-set mandrels and crank adjustments
- Nordson ProBlue hot melt glue unit with precise temperature control and energy saving timer
- Easy load, gravity tray magazine
- Self-cleaning vacuum system flushes the vacuum system every cycle, preventing corrugated dust buildup
- Self-cleaning glue guns keep glue patterns tight and on target
- Allen Bradley PLC Control with touch screen operator interface



TF-2

Sequence of Operation:

An operator loads flat tray blanks into the gravity magazine. A vacuum arm extends to the tray blank, applies suction, retracts and then moves the flat tray horizontally past two glue heads which apply a glue bead to the tray tabs. The glue application is controlled by magnetic position sensors which sense the tray position. After passing the glue heads, the transport arm extends and pushes the flat tray blank into a mandrel, forming the tray and folding the tabs. At this moment, four small cylinders extend into the mandrel, one at each corner of the newly formed tray, applying pressure and securing the glue seal. The vacuum arm then retracts and returns to the home position to pull another blank.



Combi tray erectors are an ideal solution for slotted style trays

Model	Min Tray Size: L x W x H	Max Tray Size: L x W x H	Max Blank Size: L x W x H	Machine Footprint: L x W x H	Speed
TF-2	9.5 x 8.5 x 2"	24 x 16 x 5"	34 x 26"	6'2" x 6' x 4'11"	up to 10 tpm
TF-2+	9.5 x 8.5 x 2"	24 x 16 x 9"	34 x 26"	6'2" x 6' x 4'11"	up to 8 tpm

Distributed by:

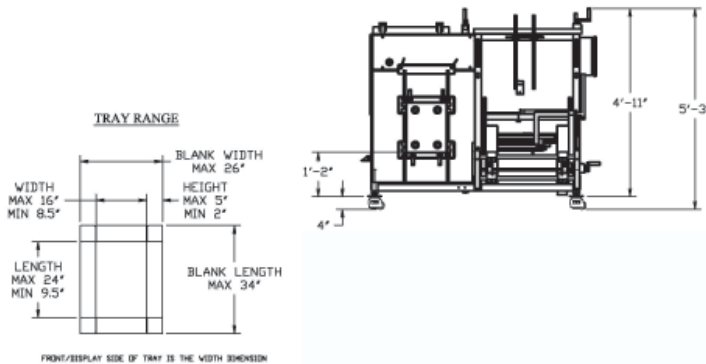
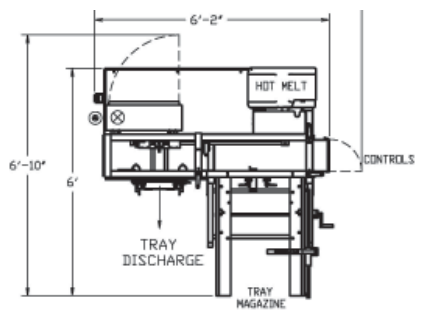

Combi
Packaging Systems LLC

5365 East Center Dr. NE Canton, OH 44721
Phone: 1-800-521-9072 Fax: 330-456-4644

www.combi.com
© 2010 Combi Packaging Systems LLC
a joint venture company with 3M and M J Maillis Group