

Ergomatic

Efficient Hand Packing Station



The Ergomatic is a value-priced, semi-automatic hand packing station solution for companies that require more throughput than manual case erecting, packing and sealing can provide. This integrated system provides optimum operator comfort by reducing lifting, reaching, stretching, bending and twisting in the packaging operation. Efficient and durable, the Ergomatic combines a case erector, a custom hand pack station and a Combi semi-automatic, top and bottom sealing case sealer into a cost effective work cell.

Why Automate Your Hand Packing Line?

- Automatic case erecting and on-demand case presentation w/finger swipe switch reduces reach and wrist movements
- Lifting of products is significantly reduced, resulting in fewer back injuries
- Quick case changeover means minimal machine downtime - ideal for short runs
- Minimizes reach and wrist movement, reducing threat of repetitive motion injuries and medical costs associated with treatment
- Safety interlocked guarding on case erector restricts access to moving parts
- Experience increased profits through increased productivity
- Easy to load, easy to access, walk-in gravity case magazine
- Hand packing assures 100% product inspection
- Mild steel frame components and steel-it paint finish provides a strong yet affordable frame



Ergomatic

equipped with Combi TBS100sa Sealer

Ergomatic

Common Applications:

- Products that require inspection before packing (meat, dairy, pharmaceutical)
- Short run or variable product sizes going into case
- Products that are difficult to handle automatically
- Packaging operations where full automation is not feasible due to the application or lack of funding

Combi IS Custom.
Custom IS Affordable.
Affordable IS Common Sense.

Model	Case Size Min. (LxWxH)	Case Size Max. (LxWxH)	Speed: Cases per Minute*	Overall System Footprint Two Person Station
Ergomatic	8½ x 4¾ x 4" (216x121x102mm)	20 x 13½ x 19½" (508x343x495mm)	12 cpm	15'10¼" x 7'4" x 5'4½" (483x224x163cm)

*speed is operator dependent

Distributed by:

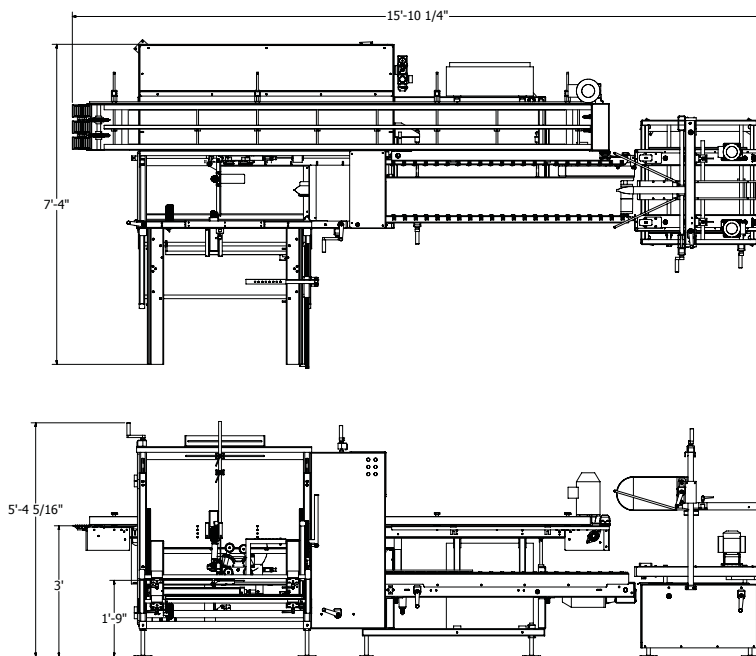

RIGHT HAND SYSTEM

Combi
 Packaging Systems LLC

5365 East Center Dr. NE Canton, OH 44721
 Phone: 1-800-521-9072 Fax: 330-456-4644

www.combi.com
 © 2009 Combi Packaging Systems LLC
 a joint venture company with 3M and M J Maillis Group